



DESIGN NOTES

2-Step Voltage Regulation Improves Performance and Decreases CPU Temperature in Portable Computers

Design Note 209

John Seago

2-step regulation allows CPU power supply optimization in portable applications. Higher CPU clock frequencies mean lower core voltages, higher supply currents and more CPU power dissipation. Regulating CPU power from 5V reduces regulator switching losses permitting a higher switching frequency. Higher frequency operation results in smaller inductor size, fewer output capacitors and better transient response. OPTI-LOOP™ compensation and a 3.5V to 36V input range make the LTC®1736 a good choice for either 1-step or 2-step configurations.

1-Step vs 2-Step Power Conversion

Traditionally, portable computer CPU voltage regulators operate over a wide range of input voltages. This 1-step regulation technique forces the power supply to operate from battery voltages as low as 8V to adapter voltages as high as 24V. This large input voltage range forces the designer to use a relatively large inductance value for the switch inductor. The large inductor value means more energy storage, so the overvoltage transient will be larger when the load current rapidly changes from high to low.

Additional output capacitance may be required to meet transient specifications.

CPU core voltages are currently in the 1.5V region. Using the 1-step approach, regulating 24V down to 1.5V forces the regulator to regulate narrow “slivers” of input current to meet the transient requirements of high speed CPUs. A 24V wall adapter forces a 6.25% duty cycle when supplying a CPU voltage of 1.5V which means that the top MOSFET conducts for 0.2μs each cycle, at 300kHz.

Using 2-step regulation, CPU voltages are regulated from the 5V system supply. Decreasing the input voltage of the core voltage regulator reduces switching losses, allowing a higher switching frequency, a smaller inductor, decreased output capacitance, wider bandwidth, easier control loop optimization and higher efficiency. High efficiency and small inductor size are very important in portable computer applications since the core voltage regulator is normally located near the CPU. Temperature rise is a big problem around the CPU, and this area tends to be very crowded.

LT, LTC and LT are registered trademarks of Linear Technology Corporation. OPTI-LOOP and Burst Mode are trademarks of Linear Technology Corporation.

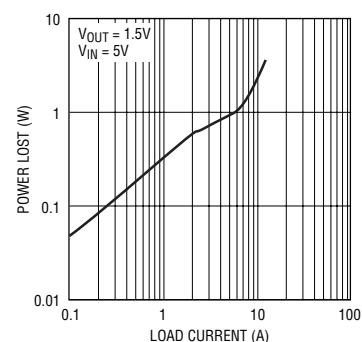
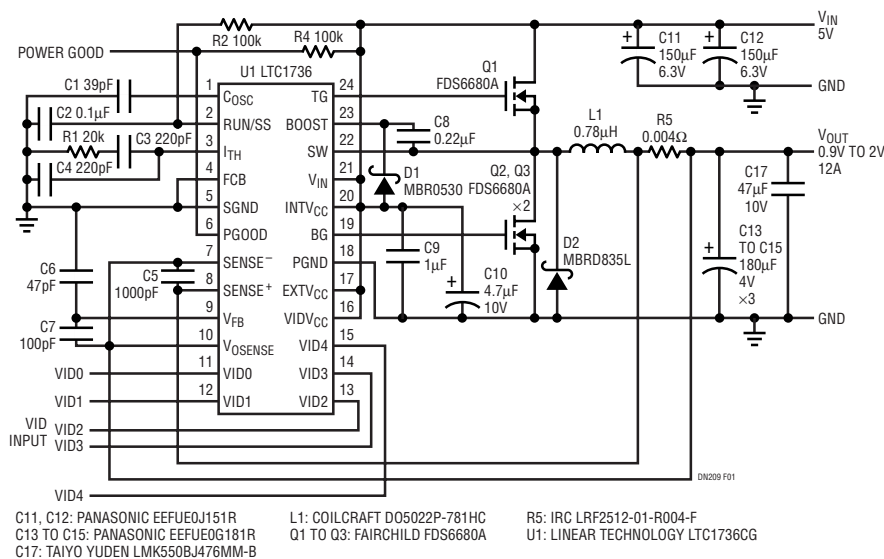

Circuit Description

The circuit in Figure 1 shows the LTC1736 featuring a 5-bit, digitally controlled output voltage, from 0.9V to 2V at 12A from a 5V input. The LTC1736 is a constant frequency current mode, synchronous-buck controller, exactly like the popular LTC1735, but with 5-bit VID and a Power Good output. Only 540 μ F of output capacitance is required for a 0.1V transient response to a 0.2A to 12A load step from a 1.5V output. The circuit power loss curve is shown in Figure 2.

The circuit in Figure 3 shows the LTC1736 circuit redesigned for 8V to 24V inputs. 720 μ F of output capacitance is required for a 0.1V transient response for a 0.2A to 12A load step from a 1.5V output. The power loss curves in Figure 4 show the effect of increased switching losses caused by higher input voltages. Increased power dissipation caused by higher switching losses increases the ambient temperature around the CPU so the CPU temperature also increases.

The versatility of the LTC1736 can be seen by comparing the two schematics. The OPTI-LOOP architecture allows both frequency response and transient response to be optimized by adjusting the compensation component values connected to the I_{TH} pin. The V_{FB} pin provides access to the error amplifier so phase lead can be added to improve transient response and increase circuit stability. Capacitor C7 provides phase lead in the circuit of Figure 1. The

LTC1735/6 are rated for input voltages from 3.5V to 36V, so inputs greater than 24V can be accommodated without concern for input voltage transients of 36V or less.

Regulator Efficiency Considerations

A common misconception is that the total efficiency of two circuits in series is the product of the efficiencies of each circuit. This is not true. Efficiency is defined as the total output power divided by the sum of the total output power plus all circuit losses.

2-step regulation takes advantage of the 5V regulator efficiency curve. The 5V supply has a peak efficiency of about 95% which is relatively flat over a wide range of load currents. The added current required to power the CPU supply causes the 5V regulator efficiency to decrease by about 1% but it also regulates the majority of the CPU power at about 94% efficiency. With a 5V input, the CPU regulator peaks at about 90% efficiency. Comparing 1-step and 2-step conversion efficiencies with a 12V input, the increased loss in the 5V regulator is about the same as the decreased loss in the CPU regulator so the overall system efficiency remains nearly constant.

The improved efficiency of 2-step regulation decreases the power dissipated near the CPU for all input voltages. The efficiency curves in Figure 4 show that more power would be dissipated near the CPU by a 1-step regulator when a higher voltage wall adapter powers the system.

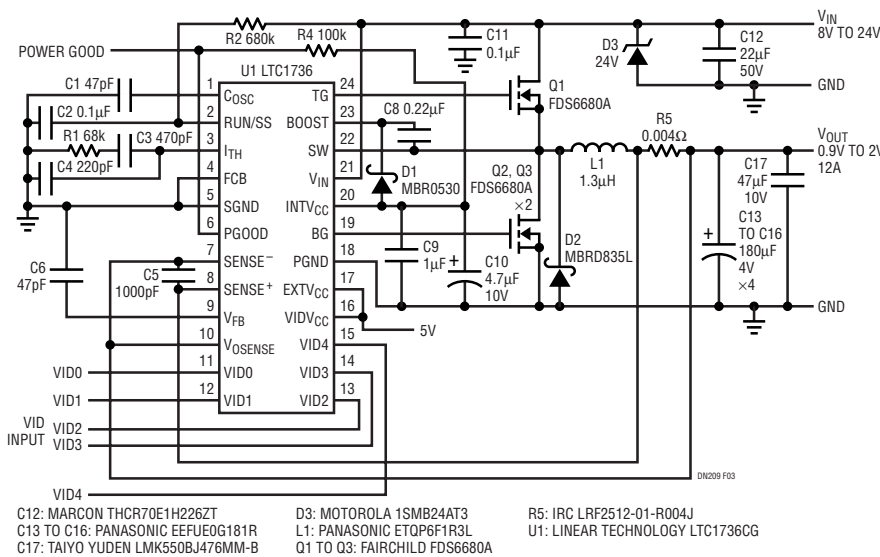

Figure 3. CPU Core Voltage Regulator for 1-Step Application

Data Sheet Download

<http://www.linear-tech.com/go/dnLTC1736>

For literature on our Switching Regulators, call **1-800-4-LINEAR**. For applications help, call (408) 432-1900, Ext. 2593

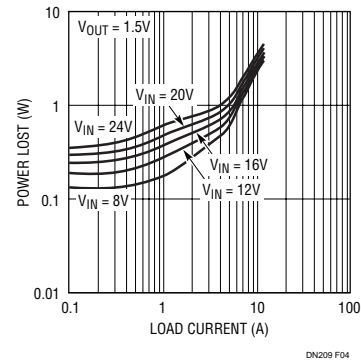

Figure 4. Power Loss Curves for 1-Step Regulator